

## System Specs

### Main Pump

- Case - Bronze
- Impeller – Bronze
- Stainless Steel hardware

### Motor

- 12 or 24 Volt DC
- 1 HP

Designed for 24 / 7 continuous duty

### System 20956 includes:

- Main Pump – Seawater bronze
- Control Panel
- Main Pump Switch

- 80 GPM Main Pump
- Auto or Manual Control
- Main Pump is mounted high and dry
- Faster, better, and less cost than a self-priming system

Small Pump discharges into the suction line of the Main Pump which keeps the Main Pump primed and ready to pump.

VS = Small Pump Check Valve  
VM = Main Pump Check Valve

Small Pump = Rule\_\_\_\_\_ DC Bilge Pump 3 GPM  
Main Pump = Scot 48378, One hp, DC Pump 80 GPM  
VS = Check Valve 1" NPT x NPT  
VM = Check Valve 1 1/2" NPT x NPT

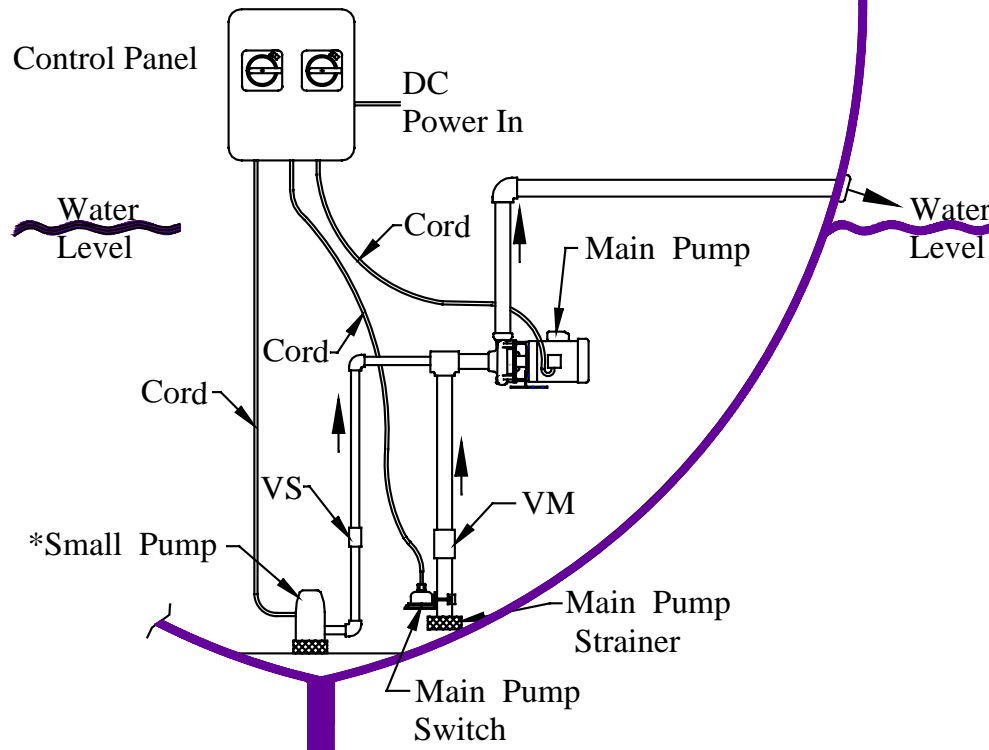

\* Small Pump is usually the vessel's existing bilge pump